

The Electric Powered Aircraft: Technical Challenges

The thought of buzzing around the sky, quietly, with no carbon emissions is an enchanting one, and is the promise of electrically powered airplanes. Just plug it in for a couple of hours and go flying. No carb ice, no oil stains, no \$4.00 a gallon av-gas. But, how close is this to becoming a reality. In this article, the technologies that are needed to make an electrically powered aircraft are explored. The goal is to describe the different types of components, the current state-of-the-art and what future developments you can expect.

Every electrically powered airplane will obviously have a motor and batteries. Yet, of equal importance are the controller, the battery management system (BMS), and the airframe matched to the electric airplane needs. These, while not as obvious, are critical to efficient power usage, battery life and safety. Let's look at each of these sub-systems.

Motors

To date, most motors being used in electric airplanes are purpose designed. Off-the-shelf motors, those developed for use in industry, electric cars and model airplanes are not generally a good fit.. Typically, model airplane motors are too small, in the 5-15kw range (note that there are 1.34 hp/kW) and industrial motors are too heavy. Electric car motors are also heavy and lack efficiency at peak horsepower needed for an airplane.

To understand what is being developed for electric airplanes, it is necessary to understand some electric motor basics. An electric motor has two major parts, a rotor and a stator. The magnets in the rotor chase the magnets in the stator causing rotation. The effective location of the magnets in either the rotor or the stator must be moved to keep the chase going.

The most common type of DC motor, a Brushed DC motor is shown in Figure 1. In the figure, the magnets in the stator are labeled with their North or South polarity- only four are shown, just a representative sample. These magnets can be permanent magnets or created by a coil of wire, i.e. electro-magnets.

Electricity is fed to rotor through the commutator. The commutator is designed so that the electro-magnets can switch polarity, by reversing the current flow. At any time the rotor magnets are attracted to and repelled from the stator magnets in such a way as to cause rotation. The commutator has segments all the way around the rotor and the stator has brushes that rub against these segments to conduct the electricity. Brushes are a weak point in this design as they can cause arcing, they wear, and they lose efficiency due to contaminants like dirt and grease. However, to make a brushed DC motor

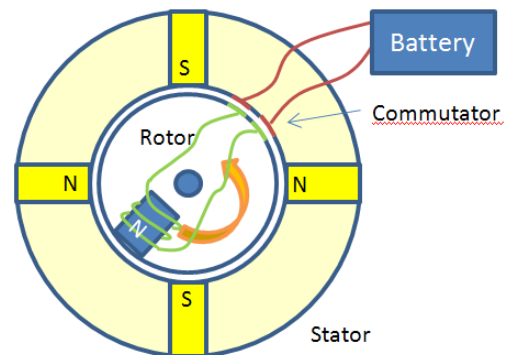

Figure 1: Brushed DC motor

run, you just need to supply current to the wires. No controller is needed, unless you want to control the speed. To control the speed you need to control the voltage, or as discussed later, the average voltage seen by the motor.

Brushless DC motors are electrically commutated eliminating the problems with brushes. This is accomplished by putting permanent magnets on the rotor and controlling the electromagnets in the stator to change polarity to attract and repel the rotor magnets as shown in Figure 2. While this configuration gets rid of the brushes, it adds a controller – both serving to alternate the polarity of the electro-magnets and their voltage level. In other words, the current flowing to the electro-magnets alternates direction to change polarity which explains why these motors are often referred to as AC motors. In the past, controllers were of analog design, but all modern controllers use digital signal processing. Brushless motors run cooler and are more efficient than brushed motors, but they cost more. The efficiency of brushless motors has improved. Also, their size and weight has decreased in recent years with the improvements in magnet technology.

Where the motors described so far have had the rotor in the middle with the stator around it, a development unique to aircraft and model aircraft motors are “outrunners” as shown in Figure 3. Outrunners have stationary inner coils of electromagnets and a rotating outer shell of permanent magnets. This creates lighter motors, runs cooling air through the middle, and provides a convenient place to mount the propeller.

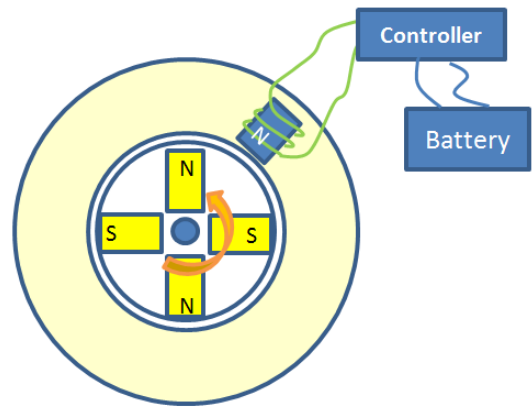

Figure 2: Brushless DC motor

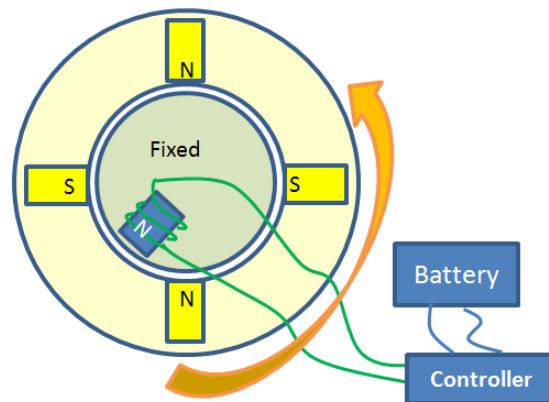

Figure 3: Outrunner Brushless DC Motor

The most refined airplane outrunner is on the Antares motor glider (See Figure 4). Its brushless 42 kW motor is powered by 288V at 160 Amps. It is about 90% efficient.

Most motors for electric airplanes are proprietary. Two companies that make off-the-shelf electric motors that may be suitable for electric airplanes are Agni Motors and Perm Motors. See the side bar for their web sites.

Batteries/fuel cells

Batteries store energy and provide it to the motor via the controller. The most important characteristic of batteries for airplanes is their energy density, usually measured in Watt hours per pound or kilogram (Wh/lb or Wh/kg), where 1 kg is 2.2 lbs. The flurry of activity in electric airplane development over the last two years is a direct result of the introduction of Lithium-ion batteries. They have better energy density than most earlier batteries and have changed everything.

Here's a simple example to help in understanding the battery's importance: Say you want to electrify your Piper J-3 Cub. You want a 65 hp engine equivalent (49kw) and you want the airplane to weigh the same as if it had the original engine, fuel tank and full load of fuel. If the electric motor and controller weigh about 50 lbs this leaves about 300 lb (136 kg) for batteries. If you used lead-acid batteries with an energy density of 30 Wh/kg (see the table below) then your batteries could supply 4,000Wh or 4 kWh. So, with your 30kw motor you can get about 8 minutes of power – just beyond the end of the runway.

Before you think too much about this example, remember that electric motors weigh just a fraction of a typical IC engine, the batteries replace the fuel and the J-3 is not the ideal electric airplane. Additionally, and this is critical, the energy density of batteries is key to the development of a viable electric airplane and lead-acid batteries aren't very good for this application. We will see that with lithium-ion batteries things get much better, allowing over an hour's flight as will be developed later in the article.

The table below lists major battery types, their energy densities and their costs. What is important here is that newer battery types like Lithium-Ion (Li) have energy densities 3-5 times greater than good-old lead acid batteries and are improving rapidly. There are many different chemistries used in Li batteries hence a wide range of values. Also shown in the table is the batteries used in the Tesla car, a Lithium formulation that is a good benchmark because they are on a production vehicle.

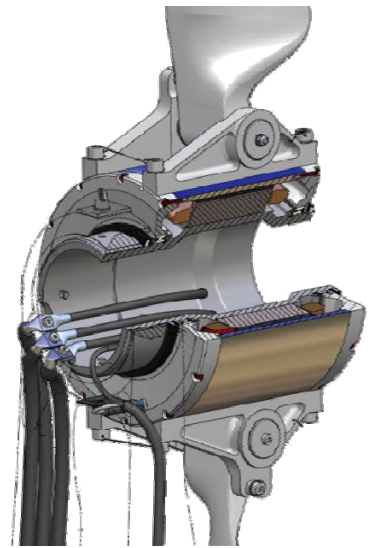

Figure 4 The Antares Outrunner motor (By permission Lange Aviation)

Battery Type	Cost \$ per Wh	Wh/kg	Wh/kg Deliverable
Lead-acid	\$0.10 -0.17	25-41	22-37
NiMH	\$0.99	50-60	45-54
NiCad	\$1.50	39	35
Lithium-ion	\$.25 – 1.00	110 -185	100-135
Tesla		185	166
Next gen Li		365	328
Theory max (Li)		5,200	4700
Av gas	\$0.14	14,000	3800

As impressive as the numbers are for Lithium batteries, their energy densities are increasing at 8% -10% a year, a doubling every ten years. The limit on this growth is the theoretical maximum of 5200Wh/kg. This will clearly never be achieved, but 365Wh/kg is expected in the next couple of years, a full ten times better than lead acid. Even better, other formulations are being developed, so this density will surely be bettered in the future.

The price of Li batteries has been very high, and is falling rapidly. I recently helped build an electric car in which \$15,000 in batteries were used. Note that the high-end price on the table includes the battery management system, which is discussed in the next section on controllers. Currently most Li batteries come from China. However, General Motors just announced that it is investing \$43M in battery manufacturing plant in Michigan.

On the last line in the table, the energy density of Av-gas is included as a reality check. Gas is very energy dense, but before you write off batteries as being an uncompetitive energy source for an airplane, consider that electric motors are 90% efficient and internal combustion engines are only about 20%. The last column of the table shows the energy densities corrected for these efficiencies. Even with this correction, batteries have a long way to go to rival Av-gas on energy density alone.

Another concern is battery life. Li batteries can charge and discharge many many cycles without losing performance. However, early Li batteries had a total life of only 4 years or so regardless of charge/discharge cycles. However, more recent batteries are claimed to 10-20 years of life, but they have not been in the field long enough to verify this.

Battery cells are not used alone but are wired together to get high voltage. Higher voltage gives higher efficiency. This is the same reason electric utility companies transfer power at very high voltage. To give you some feel for this, consider this example (from the electric car I recently worked on). The battery pack consisted of 100 Lithium-ion batteries (some of the batteries are

shown in Figure 5). Each battery is 3.2 volts so the total is 320 volts. These batteries weigh 7 lbs each for a total weight of 700 lbs (320 kg). They have an energy density of 110 Wh/kg, making a total of 35 kWh. This battery pack in an electric car is equivalent to about 1.2 gallons of gas at 100% efficiency or 6.0 gallons when corrected as described above. It is also worth noting that the batteries used in this car cost \$150 each, a total of \$15,000. But, that was a year ago. They are substantially cheaper today – prices and availability are changing fast.

Two additional sources of electrical energy need to be mentioned: solar and fuel cells. It may be practical to use solar cells to supplement the energy in an electric airplane. Current solar collectors generate about 11watts/sq ft. For a 150 sq ft wing area, this is about 1.6 kw, a little over 2 hp. For a very clean airplane like the Yuneec (see below) this can extend the flight time by about 15%. This is why Yuneec is planning on a solar cell addition to their Model 430. Additionally, the efficiency of solar cells is increasing, but with current efficiencies of 12%-20%, it is unlikely they will ever get near their ideal energy density of 100 watts/sqft. At least there is plenty of sunshine above the clouds.



Figure 5 Battery pack in an electric car showing 64 of the 100 batteries in the pack

Fuel cells are another approach for obtaining electrical energy. Effectively, they are mechanically rechargeable batteries. Batteries have all their chemistry inside, whereas chemicals constantly flow into fuel cells. Most fuel cells today use hydrogen and oxygen as the chemicals resulting in water. The efficiency of fuel cells is about 20-30% when converted to useful work. However, you need to consider that it takes energy to make hydrogen from water and round trip efficiency (from water to water) is similar to that of gasoline. As fuel cells develop, they might compete with Lithium-ion batteries and the SkySpark project in Italy is combining fuel cells with batteries for hybrid aircraft propulsion system.

A controller is needed regardless of where the electrical energy comes from, batteries, fuel cells or solar cells. As with batteries and motors, controllers have changed a lot in the recent past.

Controllers

When I first started learning about electric powered vehicles, I had no idea what a controller did or how it worked. My experience centered on using a rheostat, a big variable resistor, to control DC motors. Of course rheostats are hopelessly inefficient (key on the word resistor in “variable resistor”). What is used today is much more sophisticated.

Controllers not only change the battery energy flow in response to the throttle setting, but they protect the motor and batteries from any spikes, shorts or other anomalies that might occur in the system. Basically, all controllers use pulse width modulation to control the power to the motor. The controller turns the current supplied by the batteries off and on generating pulses, typically at 15khz. Three different set of pulses are shown in Figure 6. The 10% duty cycle produces a low speed while the 100% is full throttle. The inductance in the system acts like a damper and so the motor actually sees a

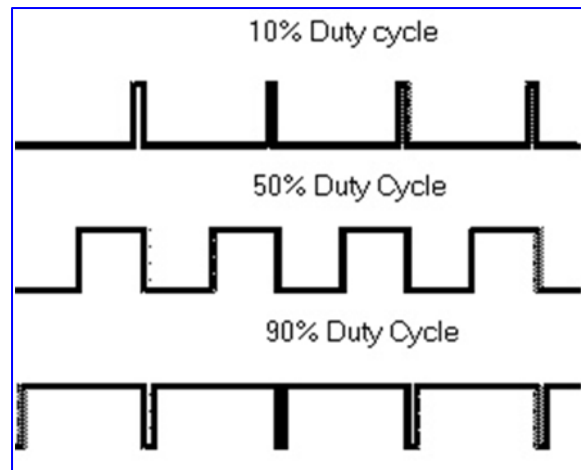

Figure 6 Pulse width modulation

very smoothed out current with a 15khz ripple.

The waviness is so small in proportion to the average power and the inertia in the system is so high that the motor runs at virtually a constant speed.

There are no off-the-shelf controllers suitable for electric airplanes at this time. This will change rapidly as the field matures.

Battery Management Systems

Lithium-ion batteries require a battery management system (BMS) to control the energy flow to and from the individual batteries, keeping them balanced and monitoring their temperature. This is necessary for safety as there are many instances of fires resulting from improper charging of Li cells. To explain why a BMS is needed consider a simple system of two batteries in a series. If wired to a motor, current will flow through both batteries as they give up energy. But, the batteries will not be identically the same and so one battery may give up energy faster than the other. Thus, when the battery that is giving up energy the fastest is empty, the other battery will try to reverse charge the empty one, damaging the cell. The same can happen when the batteries are being charged. One can charge faster than the other and may overcharge (damaging the battery and possibly causing a fire) while the other is still not up to its potential. Thus, the job of the BMS is to monitor the state of each battery and ensure that all are being treated equally to optimize the system and ensure safety.

As with controllers, BMSs are still under development with each system having a unique BMS.

Airframes

The last component to consider is the airframe. To date, most electric airplanes have been converted motor gliders with purpose built airplanes just beginning to appear (Antares 20e motor glider is the exception having been on the market for about five years). As should be obvious by now, energy is limited and so an efficient airframe is necessary. To make this article easier to relate to current aircraft, I developed a simple analytical model of three different aircraft (details in the sidebar).

The first is a Cub J-3. This is not an ideal candidate for an electric airplane, but it will make for a good starting point. For this airplane I assume that:

- The engine, fuel tank and all other power components were removed
- An electric motor, controller and BMS were installed and they weigh 50 lbs.
- The airplane carries a pilot and a passenger.
- 300 lbs of Lithium-ion batteries that produce 140 Wh/lb are installed to bring the weight back to the same as the original with full fuel tanks (1220lbs gross).
- The airplane wastes no energy on the ground (starting point is on the runway), takes off and climbs to 2,500 ft and then cruises at that altitude until it runs out of energy.

The Li batteries for this airplane store 19.1 kWh. If the Cub is flown at its recommended cruise speed of 65 mph (56 kts) it will be able to fly for 0.76 hour, about 45 minutes. If you throttle back to just over stall then you can get over 1 hour of duration. To make this conversion would cost \$10,000 - \$15,000 for the batteries alone. But, you would never have to purchase Av-gas again.

The Yuneec 430, a purpose built electric airplane, was just introduced and is still undergoing test flights. It is similar in size to the J-3 Cub - 2 place and gross weight of 1034 lb. It is composite and very clean aerodynamically. It comes with either a 6 pack of batteries or a 10 pack. The larger pack weighs 286 lbs (130kg) and is estimated to store 18kWh. It has a recommended cruise of 60 mph (52 kts). At this speed, my simple model shows it will fly for 2.0 hours. Company literature says that they estimate 2.25 – 2.5, but they haven't flown that long as of this writing. Sales are expected in 2010.



Figure 7 The Yuneec 430 (By permission - Yuneec International)

Why is the Yuneec so much better than the Cub? It has much lower drag so the power is used more efficiently. As shown in the side bar, drag is composed of induced drag and parasitic drag. The Yuneec is designed somewhere between a Cub and a motor glider – a plane designed to have both drag components as low as possible. Induced drag is directly proportional to Aspect Ratio (the span divided by the average chord or width). The Cub's is 7.0 and the Yuneec is near 14. The Antares 20E, a true motor glider with an aspect ratio of 31.7, has been successful using

electric power for launching. It has only enough stored energy to climb to about 10,000 ft although typical operation is to climb to 1,000ft and go thermal hunting, adding power only when the altitude gets too low between lifting air. Both the Yuneec and the Antares have very smooth skins and are very clean in minimizing parasitic drag.

Since flight time is directly proportional to the energy stored and the energy stored is proportional to the weight of the batteries, another metric to look at is the percent of gross weight used for batteries. For the Cub, this is 29% and for the Yuneec (with its 10 battery pack), 33%. This begs the question, of whether there is an airframe that will increase the percent battery weight further?

One potential approach is to see what happens with a larger airplane, such as an RV-10. If you replace the engine and fuel system with 80lb of electric motor and controller, and 1120 lbs of batteries, keeping the gross but only carrying 2 passengers, you have an RV-10E. This plane has 44% of its gross weight in batteries. This plane can store 71 kWh of energy, nearly four times the Yuneec or the Cub, but it takes more power to fly (hence the higher assumed motor weight). My simulation shows that it does quite well if you fly it slow. At 70mph it will stay up for 1.8 hours. If you crank it up to its cruise speed of 170 then the duration falls to 0.6 hours. However, if the 10E was streamlined and given a high aspect ratio wing then

These results imply that going bigger may not be a bad approach for an electric airplane. One drawback, however, is that the batteries for the RV-10E will cost, at today's prices upward of \$30,000. It may be, that as the price of batteries comes down and their efficiency increases, that a larger airplane makes sense. This got a friend and me to thinking about converting a DC3 and using large AC motors – then we would have the AC-DC3. Truly heavy metal.

Conclusions

The electric airplane industry is clearly in its infancy. Developments are happening fast. Its future depends on the cost and energy density of batteries. Even now, with the current cost of Av-gas at near \$4.00 per gallon, the Yuneec will fly virtually for free after a couple of hundred hours. As batteries get better and cheaper and purpose-built planes are designed, I have no fear that in the next couple of years you will see:

- 1) An electrically powered airplane will stay aloft for 2 hours carrying 2 people
- 2) An electrically powered airplane that is cost competitive for LSA and trainers
- 3) Electric airplanes will be powered by batteries with energy densities at least 50% better than those available today
- 4) An electric airplane will land at an airport near you

Sidebar

To compute the performance for the three aircraft in a uniform manner, I computed the maximum amount of stored energy for each by first subtracting the weight of the engine, fuel and payload from the Gross Weight and adding in the estimated weight of a motor and controller

(50lbs for the smaller aircraft and 80 for the RV-10e – educated guesses). The remaining weight is assumed batteries with energy density of 140 Wh/kg.

To compute energy use for constant level flight at different speeds, I estimated the power versus velocity curve for each aircraft. I assumed a general equation for power used to overcome parasitic and induced drag. I assumed that cruise velocity data published for the airplanes was at 65% power and flight at a speed just above stall was at 30% power. I used a basic parasitic plus induced drag equation to these two points with following results. Where I had other information, I verified these equations as best as possible. They are certainly accurate enough for the comparisons made in this article. Note that power is HP and velocity is mph.

Cub J-3	$P = .0000835 * V^3 + 426 / V$
Yuneec	$P = .0000505 * V^3 + 36 / V$
RV-10	$P = .0000201 * V^3 + 2880 / V$

To compute the time aloft, the energy stored in the batteries is used to lift the weight of the airplane to 2500ft and then the planes use power based on the equations until the energy is used up, the time of flight reported in the article.

Sources

The Antares - http://www.lange-aviation.com/htm/english/products/antares_20e/antares_20E.html

Agni Motors - <http://www.agnimotors.com/>

Perm Motors - http://www.perm-motor.de/index_en.php

Yuneec - http://yuneecco.uk.site.securepod.com/Aircraft_specification.html

Thanks to Otmar Ebenhoech of Café Electric and Dean Sigler for their help with the details of this article.

The author

David Ullman (EAA 0446096) is a retired Mechanical Engineering Professor and author of books on mechanical design and decision making. He is building a Velocity SE-FG and expects to be flying in 2011. He previously expected to be flying in 2009. Photo is current state of Velocity in its hangar, or rather garage which is 15 ft off the ground (he lives on a steep hill). Never hurts to get a running start.

